

1	Type	Board lens	
2	Resolution	5MP	
3	Image Format	1/2.5"	
4	Image Circle	φ7.2mm(MAX)	
5	EFL	3.6mm	
6	TTL	21.80mm	
7	F/NO.	2.0	
8	FFL (M)	4.85mm	
9	BFL (O)	6.70mm	
10	For Sensor	1/2.5"	OV9716
11	F.O.V	Horizontal	114° 74°
12		Vertical	80° 52°
13		Diagonal	156° 91°
14	TV Distortion	<-10%	<-5%
15	Relative Ill.	>65%	
16	Chief Ray Angle	<20°	
17	M.O.D	0.1m~∞	
18	Mount Type	M12*P0.5	
19	Dimension Figure	φ14.0*L16.95mm	
20	Lens Structure	6G	
21	IR-Filter	Non-IR	
22	Waterproof	No	
23	Weight	5.2g	
24	Iris Operation	Fixed	
25	Zoom Operation	Fixed	
26	Focus Operation	Manual	
27	Operating Temperature	-20° ~+85°	
28	Storage Temperature	-20° ~+85°	

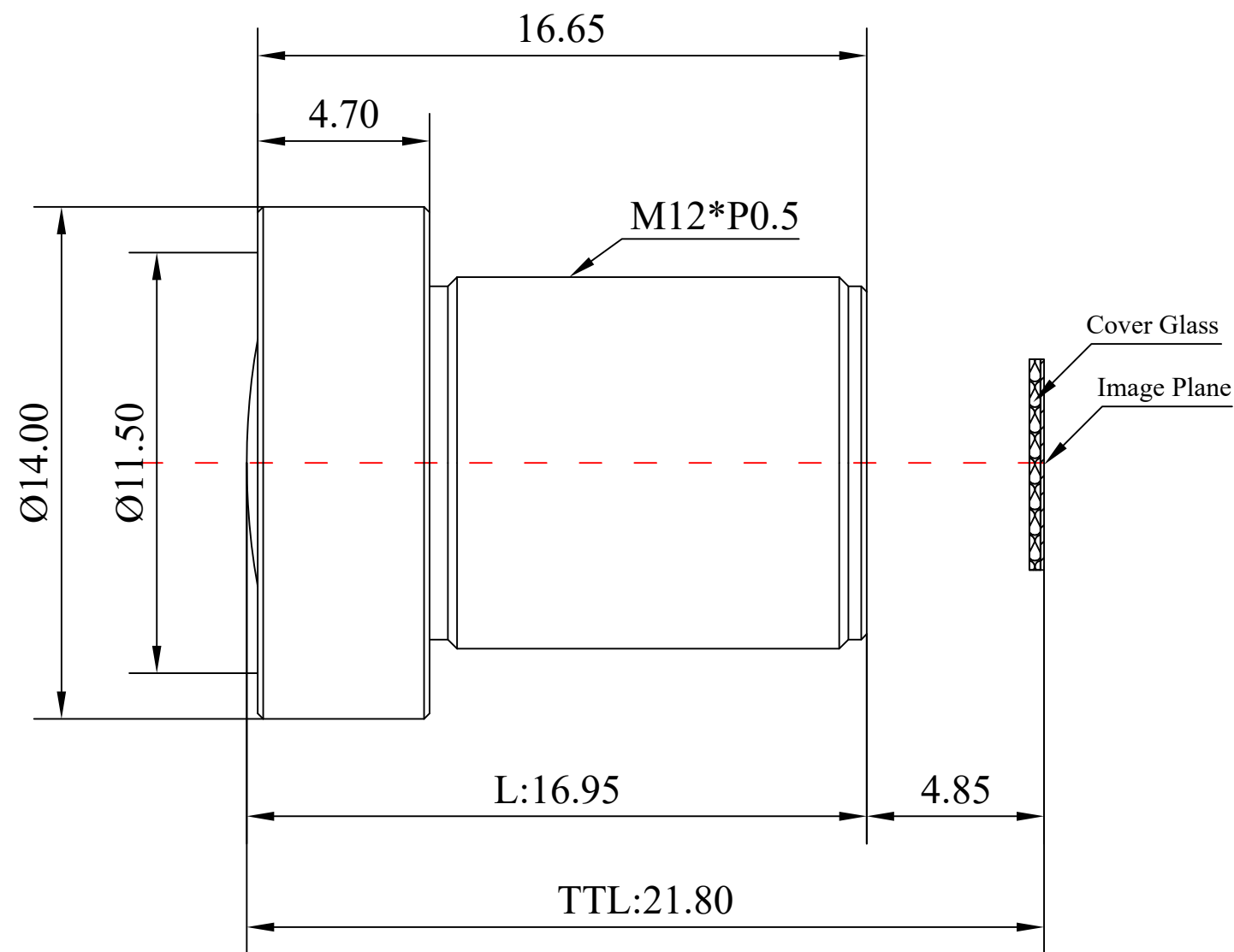
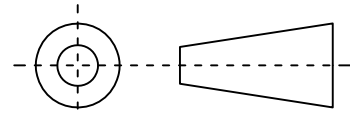

Scale	Remark	Tolerances	Date	Revised		福州创安光电科技有限公司 FUZHOU CHUANGAN OPTICS CO., LTD
5:1	X	±0.2	2018-01-13	CH891A Rev1.0		
	X.0	±0.15				
Units	X.00	±0.10	Design	Linda	2017-06-17	 3D Angle Projection
	X.000	±0.001	Checked	Anna	2017-08-14	
mm	Angle	±0.5°	Approval	Sanmu	2017-08-21	