

1	Type	M10 Lens		
2	Resolution	8MP		
3	Image Format	1/2.3"		
4	Image Circle	Ø7.9mm(MAX)		
5	EFL	16mm		
6	TTL	21.66mm		
7	F/NO.	F5.6		
8	FFL (M)	4.0mm		
9	BFL (O)	8.93mm		
10	For Sensor	AR0234	IMX577	
11	F.O.V	Horizontal	19.8°	22°
12		Vertical	12.3°	16.5°
13		Diagonal	23.2°	27°
14	TV Distortion	<0.31%		
15	Relative Ill.	>93%		
16	Chief Ray Angle	<10°		
17	M.O.D	0.1m~∞		
18	Mount Type	M10*P0.5		
19	Dimension Figure	Ø10.0*L18.25mm		
20	Lens Structure	6G		
21	IR-Filter	Non-IR		
22	Waterproof	No		
23	Weight	/		
24	Iris Operation	Fixed		
25	Zoom Operation	Fixed		
26	Focus Operation	Manual		
27	Operating Temperature	-25° ~+85°		
28	Storage Temperature	-25° ~+85°		

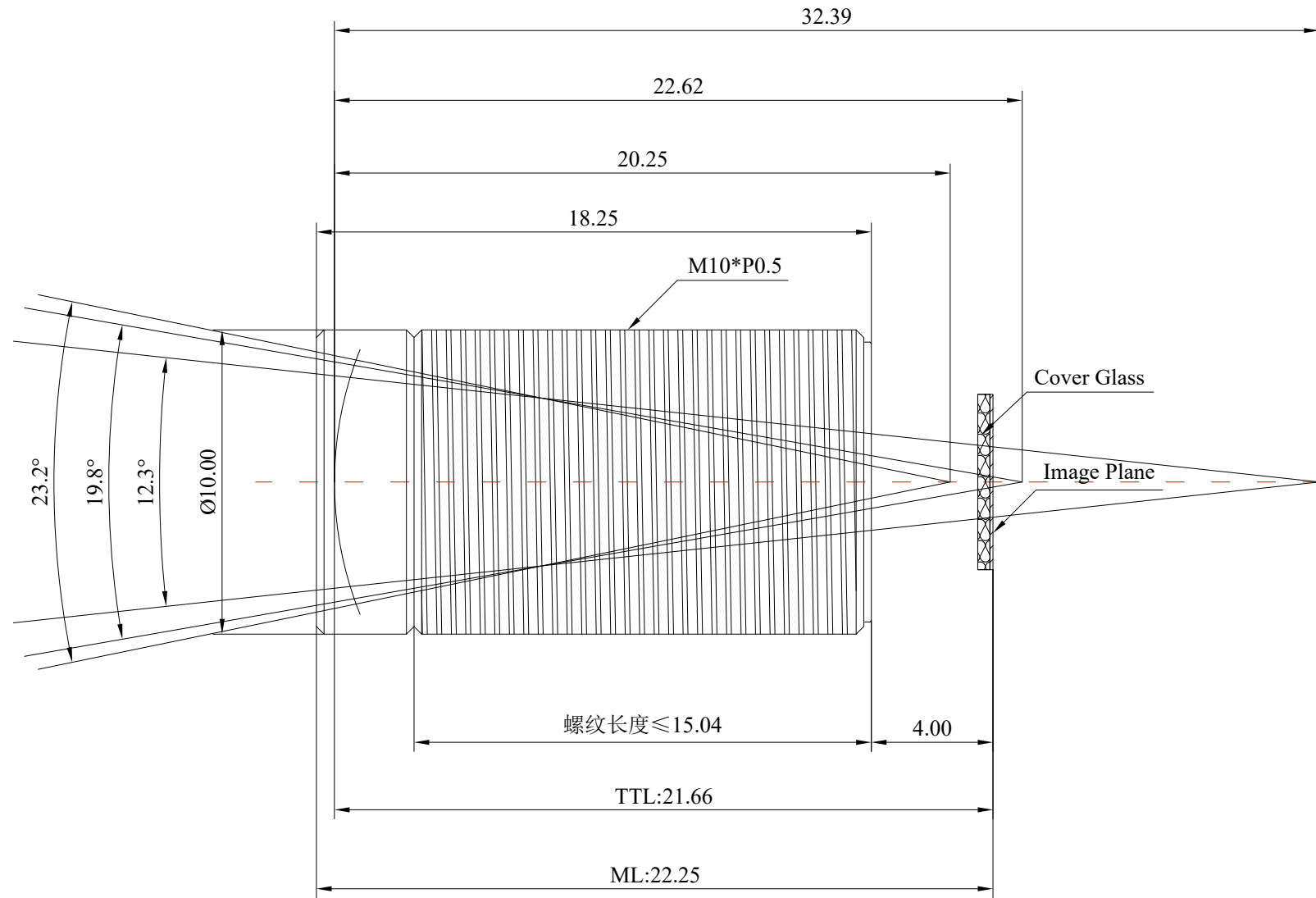

Scale	Remark	Tolerances	Date	Revsied		福州创安光电科技有限公司 FUZHOU CHUANGAN OPTICS CO., LTD
4: 1	X	±0.2	2026-03-26	CH8184A Rev1.0		
	X.0	±0.15				
Units	X.00	±0.10	Design	Linda	2026-01-23	
	X.000	±0.001	Checked	Anna	2026-03-15	
mm	Angle	±0.05°	Approval	Sanmu	2026-03-21	

