

1	Type	M5 Lens	
2	Resolution	5MP	
3	Image Format	1/5"	
4	Image Circle	φ3.92mm(MAX)	
5	EFL	1.46mm	
6	TTL	4.0mm	
7	F/NO.	F2.2	
8	FFL (M)	0.84mm	
9	BFL (O)	0.88mm	
10	For Sensor	1/5"	
11	F.O.V	Horizontal	97°
12		Vertical	76°
13		Diagonal	120°
14	Distortion	OPT:<-27% TV:<-15%	
15	Relative Ill.	>29.2%	
16	Chief Ray Angle	<32.4°	
17	M.O.D	0.1m~∞	
18	Mount Type	M5*P0.25	
19	Dimension Figure	φ5.0*L3.16mm	
20	Lens Structure	5P	
21	IR-Filter	IR650nm	
22	Waterproof	No	
23	Weight	---	
24	Iris Operation	Fixed	
25	Zoom Operation	Fixed	
26	Focus Operation	Manual	
27	Operating Temperature	-15° ~+45°	
28	Storage Temperature	-15° ~+45°	

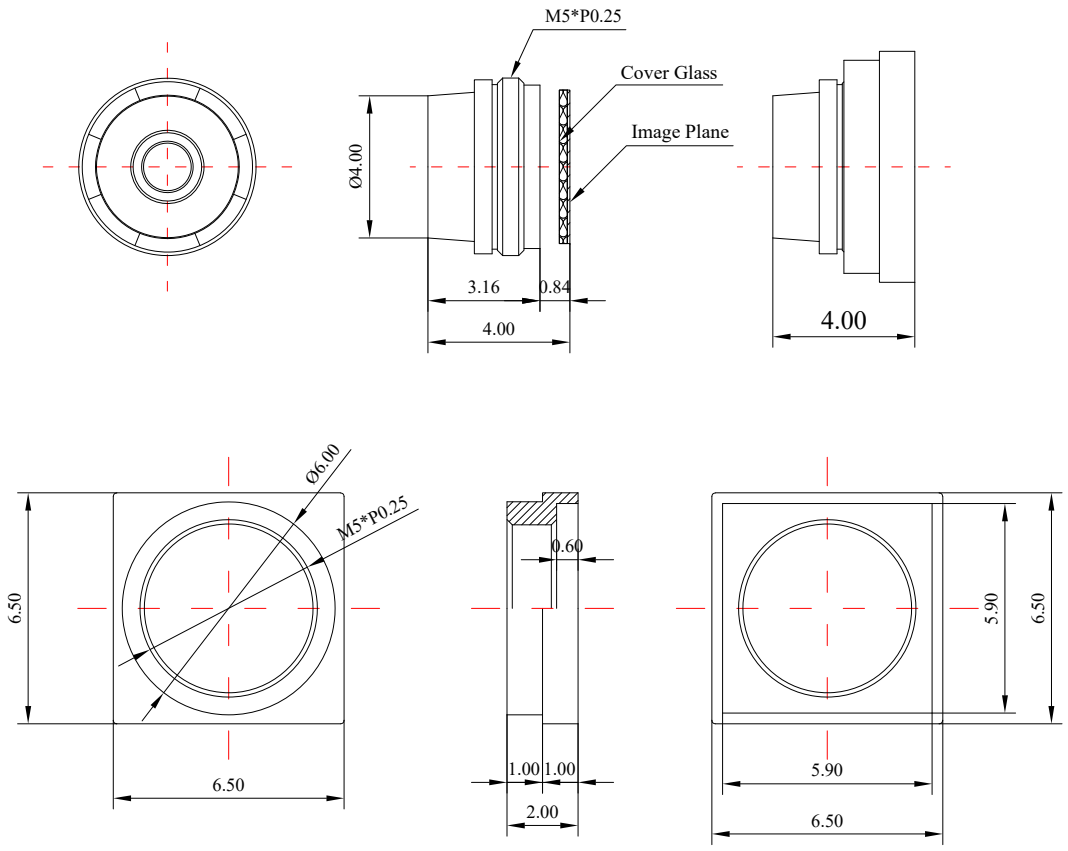

Scale	Remark	Tolerances	Date	Revised	
4:1	X	±0.2	2024-03-18	CH8072AB Rev1.0	
	X.0	±0.15			
Units	X.00	±0.10	Design	Linda	2024-02-27
	X.000	±0.001	Checked	Anna	2024-03-11
mm	Angle	±0.5°	Approval	Sanmu	2024-03-17

福州创安光电科技有限公司  
FUZHOU CHUANGAN OPTICS CO., LTD

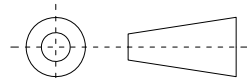

3D Angle Projection