

1	Type	Machine vision Lens			
2	EFL	35mm			
3	F.NO	F2.8~22			
4	Resolution	20MP			
5	Image Format	1.1"			
6	BFL (M)	17.53			
7	For Sensor	1.1"	1"	2/3"	
8	F.O.V	Horizontal	22.6°	20.6°	14.3°
9		Vertical	17°	15.45°	10.7°
10		Diagonal	28.3°	25.75°	17.86°
11	TV Distortion	<0.02%	<0.02%	<0.02%	
12	M.O.D	0.1m			
13	Mount Type	C/CS			
14	Dimension Figure	φ38.00*L51.60			
15	Filter Size	M35.5*P0.5			
16	Weight	---			

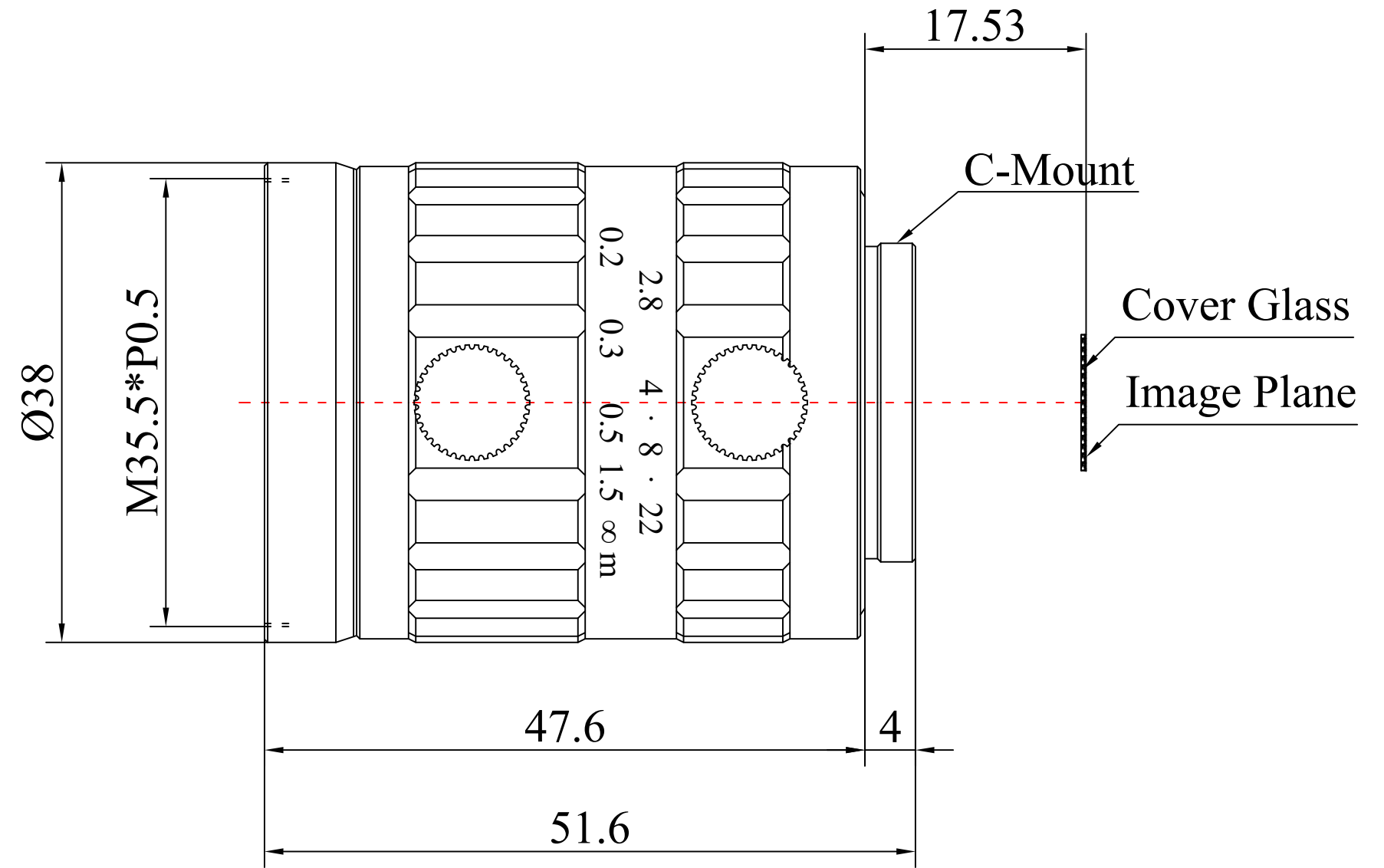
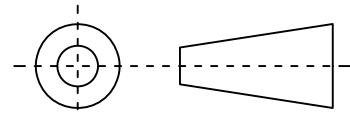

17	Iris Operation	Manual	Scale	Remark	Tolerances	Date	Revised		福州创安光电科技有限公司 FUZHOU CHUANGAN OPTICS CO., LTD	
18	Zoom Operation	Fixed		1.5 : 1	X	±0.2	2021-01-15	CH605A Rev1.0		
19	Focus Operation	Manual		Units	X.00	±0.10	Design	Linda		2016-02-10
20	Operating Temperature	-20° +85°	mm	X.000	±0.001	Checked	Anna	2016-05-07	 3D Angle Projection	
21	Storage Temperature	-20° +85°		Angle	±0.5°	Approval	Sanmu	2016-05-28		