

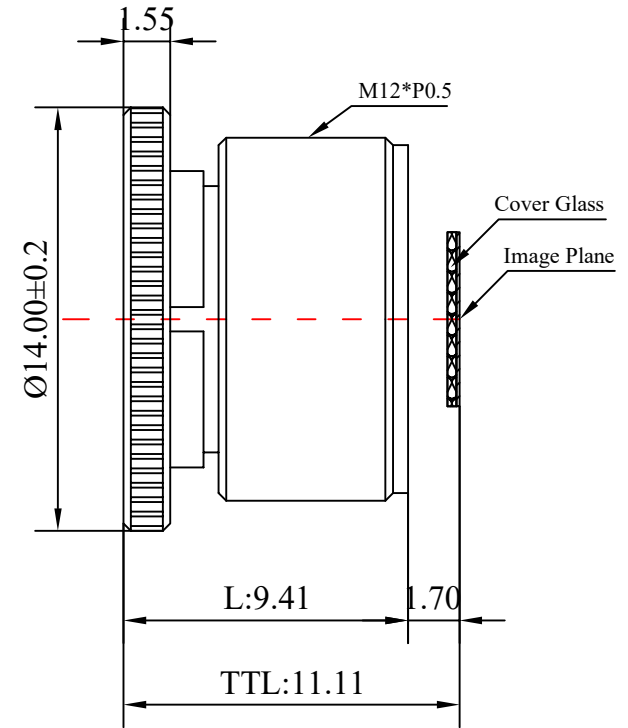

PRODUCT: CH3624D

1	Type	Scan lens	
2	Resolution	MP	
3	Image Format	1/2.5"	
4	Image Circle	φ7.2mm(MAX)	
5	EFL	7.45mm	
6	TTL	11.11mm	
7	F/NO.	6.0	
8	FFL (M)	1.70mm	
9	BFL (O)	2.11mm	
10	For Sensor	1/2.5"	
11	F.O.V	Horizontal	43°
12		Vertical	35°
13		Diagonal	55°
14	TV Distortion	<-1%	
15	Relative Ill.	>50%	
16	Chief Ray Angle	<22°	
17	M.O.D	0.1m~∞	
18	Mount Type	M12*P0.5	
19	Dimension Figure	φ14.0*L9.41mm	
20	Lens Structure	2G2P	
21	IR-Filter	T=50%&IR650±10nm	
22	Waterproof	No	
23	Weight	1.3g	
24	Iris Operation	Fixed	
25	Zoom Operation	Fixed	
26	Focus Operation	Manual	
27	Operating Temperature	-10° ~ +65°	
28	Storage Temperature	-10° ~ +65°	

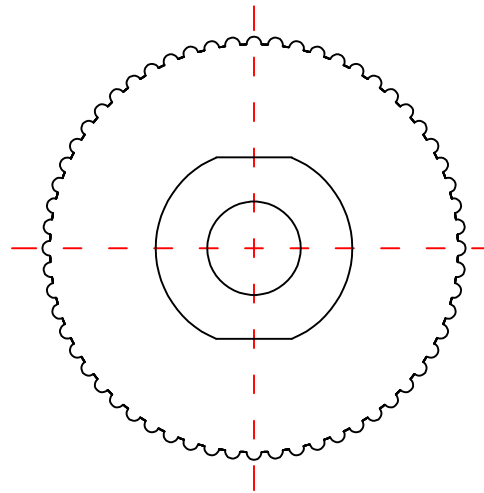

Scale	Remark	Tolerances	Date	Revised		福州创安光电科技有限公司 FUZHOU CHUANGAN OPTICS CO., LTD
5:1	X	±0.2	2019-12-09	CH3624D Rev1.0		
Units	X.00	±0.10	Design	Linda	2019-08-10	 3D Angle Projection
	X.000	±0.001	Checked	Anna	2019-09-19	
mm	Angle	±0.5°	Approval	Sanmu	2019-11-03	