

1	Type	Low Distortion Lens	
2	Resolution	8.8MP	
3	Image Format	1/2.3"&1/3"	
4	Image Circle	φ8.1mm(MAX)	
5	EFL	4.35mm	
6	TTL	22.05mm	
7	F/NO.	3.0	
8	FFL (M)	2.15mm	
9	BFL (O)	3.65mm	
10	For Sensor	1/2.3"	AR0230
11	F.O.V	Horizontal	73° 66°
12		Vertical	56° 41°
13		Diagonal	86° 75°
14	TV Distortion	<-1.2%	<-1.0%
15	Relative Ill.	>75%	>80%
16	Chief Ray Angle	<15°	<13°
17	M.O.D	0.1m~∞	
18	Mount Type	M12*P0.5	
19	Dimension Figure	φ14.0*L19.90mm	
20	Lens Structure	4G2P	

IR No.:CH6089A

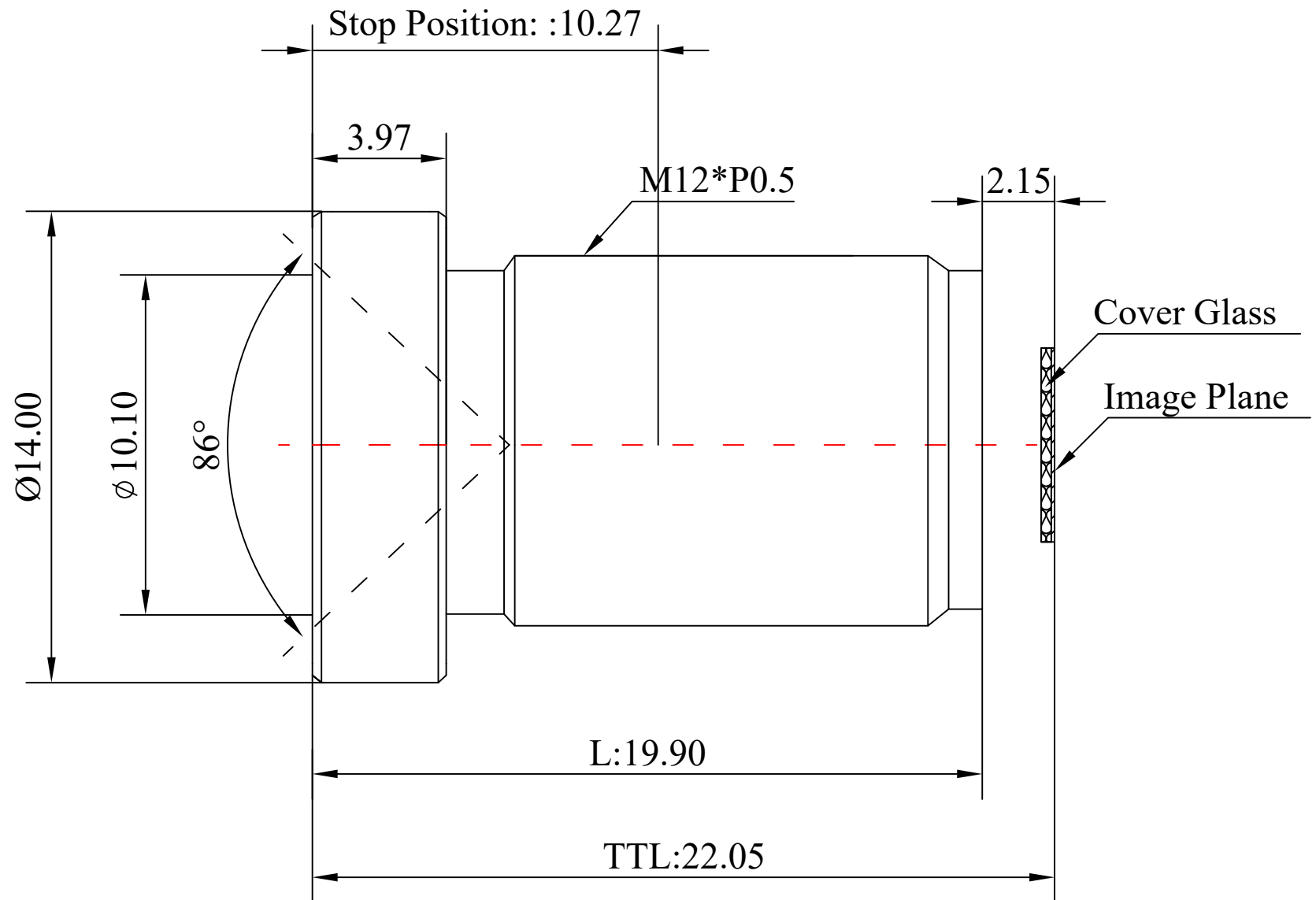

21	IR-Filter	IR475+550+850nm						
22	Weight	9.5g	Scale	Remark	Tolerances	Date	Revised	
23	Iris Operation	Fixed	4: 1	X	± 0.1	2019-07-07	CH1100EG Rev1.0	
24	Zoom Operation	Fixed		X.0	± 0.05			
25	Focus Operation	Manual	Units	X.00	± 0.03	Design	Linda	2018-08-17
26	Operating Temperature	-20° ~+85°		X.000	± 0.001	Checked	Anna	2018-09-25
27	Storage Temperature	-20° ~+85°	mm	Angle	± 0.5°	Approval	Sanmu	2018-10-20

 福州创安光电科技有限公司  
 FUZHOU CHUANGAN OPTICS CO., LTD
